

ELECTRONIC CURRENT AWARENESS SERVICE (E-CAS) IN A NETWORKED ENVIRONMENT FOR LIBRARIES

by

Soundararajan E*
Joseph J.V.M **
Jayakumar C**
Dr. Venkadesan S**

ABSTRACT

The advancement in communication and networking technologies and the adaptation of Internet and Intranet Technologies in organizational networks has given the Library and Information Centers an opportunity to improve the information services to the patrons in more effective way. This paper describes the culmination of Current Awareness Service (CAS) and Selective Dissemination of Information (SDI) into delivery of user need based recent additions of book titles and other documents into patrons email accounts periodically. The system design and implementation aspects are explained covering SMTP and Java Servlet Programming. The application is being introduced and tested in Indira Gandhi Centre for Atomic Research where the networked infrastructure and the active user base are available.

Keywords: Information Systems; Current Awareness Service (CAS); Selective Dissemination of Information (SDI); Simple Mail Transfer Protocol (SMTP); Java Servlet; User Profile; Intranet Information Services; Networked Society

* Indira Gandhi Centre for Atomic Research, Kalpakkam

** Indira Gandhi Centre for Atomic Research, Kalpakkam

0 Introduction

Current Awareness Service of a library aims at providing information about recent arrival of books, journals and other library documents to the library members. This is usually done at libraries by taking printout list and displaying on notice board and circulating this list among various departments. This Method has limitation of reach ability of the information and the time constraints. Also Selective Dissemination of Information (SDI) meaning delivery of the user need specific Information is very difficult. These difficulties are overcome in the E-CAS method of Current Awareness Service, which combines both CAS and SDI together and makes the information about new arrival of documents available to the library patrons periodically using email facility.

1 Information Services

Information Service Section of a library primarily aims at providing effective and efficient information services on library documents, databases and other information resources available over the network and Internet. This service may be achieved using several methods like providing desktop access to information resources, making available the information databases (like bibliographic, full text) over the network, email services, Current Awareness Services, Selective Dissemination of Information services, Online Public Access Catalogue (OPAC) etc.

1.1 Current Awareness Service (CAS)

The Current Awareness Service of a library keeps its patrons updated with the latest collections. CAS is very much required where there is a continuous need of current affairs and developments by the users. More continuous the need, more is the Current Awareness Service needed. CAS is a direct link between users and the communicator through communication system or devices. The system or device is called CAS. CAS involves time lag. There is no fixed time limit. Information should reach the user as soon as possible.

1.2 Selective Dissemination of Information (SDI)

Information dissemination applications are gaining increasing popularity due to dramatic improvements in communication bandwidth and ubiquity. The sheer volume of data available necessitates the use of selective approaches to dissemination in order to avoid overwhelming the users with unnecessary information. SDI is an information retrieval technique that enables users to receive relevant information automatically, on a regular basis through profiles that reflect their information needs.

1.3 Email Based Information Delivery

Email, nowadays, is a highly efficient high speed and instant method for information exchange. Email could be applied in the correspondence related to acquisition, circulation, reference, documentation, reservation intimations, reminders, current awareness service, SDI inter and intra library communication and administrative services etc. Visualising the advantages of E-mail, library and information services should harness it as an information exchange tool.

1.4 Networked Environment

Networked Environment could mean an intranet, which is a set of Local Area Networks (LANs) within an organization. More widely, it could also mean Internet. There are some library networks like INFLIBNET, NICNET, DELNET, CALIBNET, MALIBNET, SIRNET etc which all provide a library based networked environment. The performance of the Networked environment is determined by the factors of hardware (Switches, Routers and Servers) and Software (Operating System, Application Programs). Designing and establishing the infrastructure for a suitable networked environment in a library is more important and could have impact on its information services.

2 What is E-CAS ?

E-CAS means implementing the CAS electronically using the Email facility. E-CAS can combine both CAS and SDI together. This is possible by creating E-Profile for the users . E-Profile may consists of user details such as user name, email ID, Subjects of interest, etc. The created profiles can be stored in a database system. E-CAS system tracks everyone's profile for their matching entries in library database such as new arrival of books on specified subject, new arrival of journals, newly added CDs etc. This information is composed into mail messages and sent to respective users periodically. Thus users get current awareness service on their desktop with SDI.

3 E-CAS at IGCAR Library

Indira Gandhi Centre for Atomic Research (IGCAR) is one of the major Research and Development facility having 25 primary laboratories in Nuclear Science & Technology under the Department of Atomic Energy, Govt. of India. The Library and Information Services at IGCAR is a research library catering to the needs of more than 3000 patrons, most of whom are scientists and engineers involved in R&D. The Library has currently about 60,000 books, 200,000 reports, and 720 periodicals.

Library and Information Services of IGCAR are equipped with switched 100/10 Mbps CD-ROM based local area network with latest computers for speedy access to information. The Library facilitates its users to access a wide range of Scientific and Technical information in a networked environment. Various servers are connected to library Local Area Network (LAN), which in turn are connected to campus backbone through ATM uplink. The IGCAR library network is depicted in fig1.

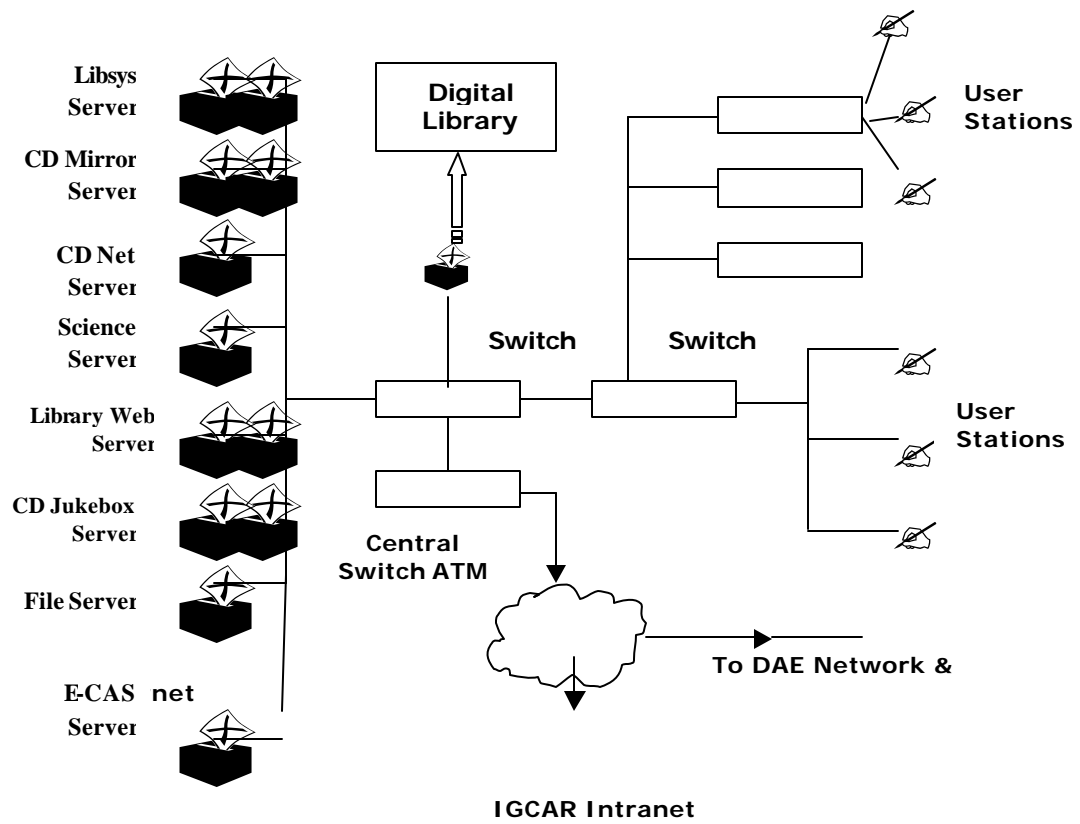

Fig: 1 IGCAR Library Network

3.1 E-CAS Architecture at IGCAR Library

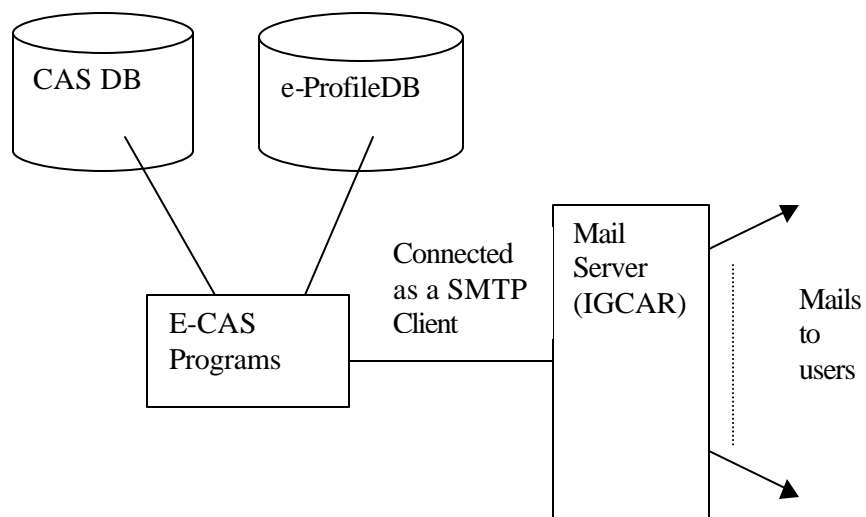

Fig 2: The Architectural diagram of E-CAS at IGCAR

The architecture of E-CAS system at IGCAR Library is shown in fig 2.

A group of programs written using java Servlet takes care of CAS with SDI. CAS DB contains the recent arrivals for various documents such as books, journals, reports, CDs etc. E-Profile DB contains the profiles of users. The E-CAS Servlets after querying and getting information for each user from CAS DB composes mail messages customized with the user name and other details and dispatch these mails to the Mail Server of IGCAR using SMTP protocol.

3.2 User Profiles

A user profile consists of several fields to be filled. A sample screen shot of a user profile at IGCAR Library is shown in fig 3. After doing a through validation, the e-Profile of the user is stored into the PROFILE DB.

The screenshot shows a web browser window titled "PROFILING AND TRACKING - Microsoft Internet Explorer". The address bar shows "http://krishna/create.htm". The page content is a form titled "Create Your Profile". The form fields are as follows:

- IC NO: 6088
- Library Member No: 4379
- Title: Mr.
- Name: Sundararajan E
- Email Id: sundar@igcar.ernet.in
- (Enter Name in the format Like Sundararajan E)
- Password: [blacked out]
- Re Enter Password: [blacked out]
- Subjects Of Interest (Like Nuclear Science, Computer Science, General etc.)
- 1. Computer Science
- 2. Electronic Engineering
- 3. Instrumentation
- 4. (General Subject) Library Science
- I Want Reports List on Display Periodically
- I Want New Arrival Journals Periodically
- I Want New Arrival CD Titles Periodically

At the bottom of the form are "Submit" and "Reset" buttons.

Fig 3: A sample User Profile

3.3 Information Delivery from E-CAS

After creating profile, E-CAS system tracks the profile periodically and sends the CAS with SDI information to the user as an email message. A sample message generated by E-CAS at IGCAR library is given in fig 4.

3.4 Profile Updation Feature

The option to update the profile of the user is also made available, so that user can disable the mail services in case he/she does not require it, change the subjects of interest etc. and has the option to drop the profile

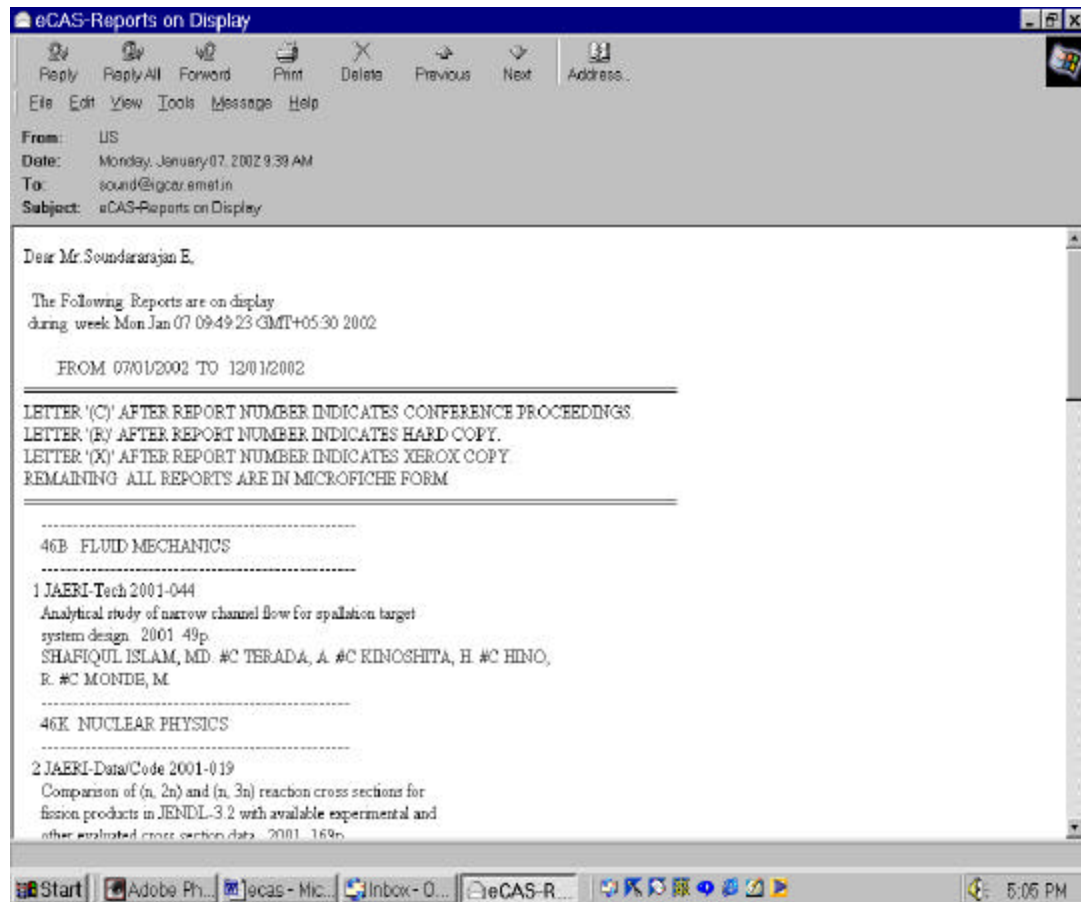

Fig 4: A Sample Email generated by E-CAS at IGCAR

4 System Design

E-CAS is basically a web-based system. As seen from the above diagrams, E-CAS uses Web Browsers for obtaining the e-Profiles of the users. The reason for providing web-based solutions is that it is easy and reaches clients without any special installation.

The Web Server such as Internet Information Server or Apache sits between the HTTP requests (User Requests From Browser) and the Server Scripts such as Servlets, ASP etc. Apache Web server is used at IGCAR Library to service the e-Profile requests. On the server side, java Servlets are used to validate e-Profile requests and build Profile Data Base. Data Base to Servlets connectivity is established using JDBC-ODBC bridge driver Interface.

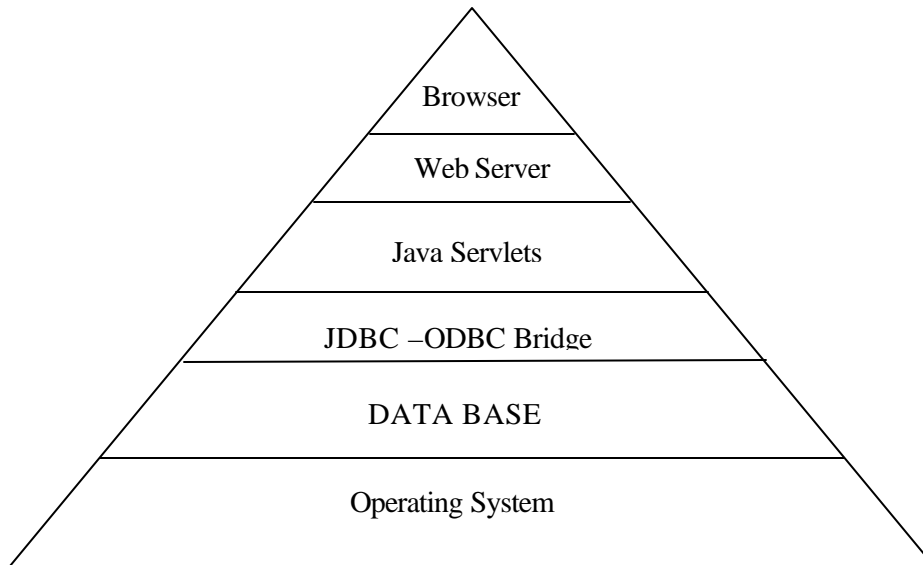

Fig 5: System Design aspect of E-CAS at IGCAR

The SMTP Protocol is used by the Servlets of E-CAS to communicate with the Mail Server for sending the E-CAS mails. The Objective of SMTP is to transfer mail reliably and efficiently.

SMTP is independent of the particular transmission sub system and requires only a reliable data stream channel. An important feature of SMTP is it's capability to relay mail across transport service environments. A transport service provides an inter process communication environment (IPCE). An IPCE may cover one network, several networks or a subset of network. It is important to realize that transport systems (or IPCE) are not one to one with networks. A process can communicate directly with another process through any mutually known IPCE. Mail is an application or use of Inter Process Communication.

Mail can be communicated between processes in different IPCEs by relaying through a process connected to two (or more) IPCEs. More specifically, mail can be relayed between hosts on different transport systems by a host on both transport system.

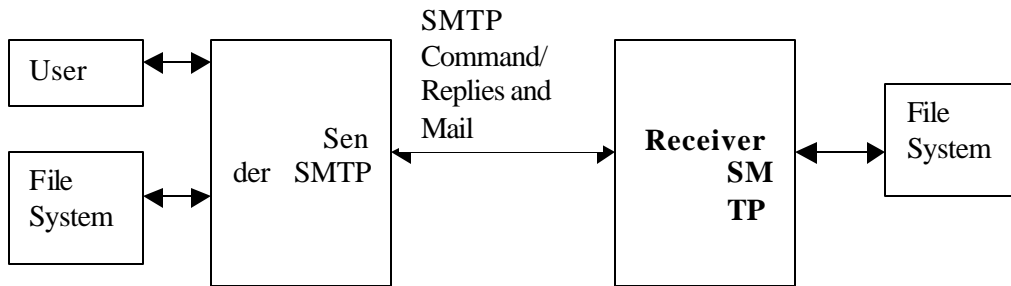

Fig 6: The SMTP Model

5 Conclusion

As the information technology is emerging, Library and Information Professionals need to adopt the latest technological tools in order to provide efficient information services. E-CAS which combines both CAS and SDI will reduce the pressure for L&IS professional having to manually do CAS & SDI and also provides the desktop availability of new documents to the library patrons.

6 References

1. HUNTER (JASON) and CRAWFORD (WILLIAM). Java Servlet Programming. O'Reilly, 2000.
2. <http://www.lanfield.com/rfcs/rfc821.html>
3. VENKADESAN (S) and NARAYANAN (A). Digital Library initiative in an Indian Research Library: An experience Report. Proceedings of the Conference on Recent Advances in Information Technology (READIT-99). October 28-29, 1999. p 111-125.
4. VIJAY KUMAR et. al. Email: A tool for Exchange of Information in Libraries. Proceedings of the Conference on Library and Information Networking. NACLIN 2000, December 24-25, 2000. p 300-309.
5. SHARMA (R K) and ARYA (S B). Documentation Information Science and Automation in Libraries. 1998. Y K Publishers.